

Date : 25/06/2017

Version : 1.5

Teaching Maturity Model (TeaM)

Elisa Reçi and Andreas Bollin

Institute of Informatics Didactics, Alpen-Adria Universität,
Universitätstr. 65-67, 9020 Klagenfurt, Austria
{elisa.reci, andreas.bollin}@aau.at
<http://iid.aau.at/>

1 Introduction

The TeaM model is ongoing project running at the institute of Informatics didactics at University of Klagenfurt. It was built up from the necessity of some standards to address the quality of teaching, with the focus on the teaching process and in regard to teachers at university, primary and secondary schools. The applicability of the model can help either the education institution to evaluate and improve its quality of teaching (by, when required producing a ranking), or it helps teachers to evaluate and improve their teaching process. In order to come up with the TeaM model, three types of resources (literature review (books), CMMI [2], and the T-CMM model [1]) were investigated. In a follow-up step, we evaluate the TeaM model by a CMMI expert and we planned to verify the resulting model by arranging a qualitative study. In the first step, a definition of the teaching process (see Fig.2) was established, and by elaborating the sub-phases of each phase of the teaching process, comparing them also to CMMI and T-CMM, the ground activities and goals of the models were defined (see Fig.1). This data helped to build up a questionnaire, used for conducting a qualitative research with internal and external lectures (teachers). The aim was to test the understandability and acceptability of the model and to collect a set of best practices from the experience of the involved teachers. By analyzing and processing the research results, the TeaM model was built.

Capability Maturity Model Integration (CMMI) As the major terminology of the TeaM Model is based on CMMI, we briefly introduce the basic items of CMMI in this section. CMMI consists of several components, divided into *Process Areas* (PAs). Each PA cluster a set of *Specific Practices* (SP), that when implemented, satisfy a set of *Specific Goals* (SG), and this is unique to one particular PA. Meanwhile, all the PAs cluster a set of *Generic Practices* (GP), then when implemented satisfy a set of *Generic Goals* (GG), and these are the same for all the PAs. The generic concept covers the meaning of process institutionalization. The implementation of both, specific and generic components is observed in two representation levels: *Capability Level* (CL) (only one PA is considered) and *Maturity Level* (ML) (a set of PAs are considered) [2].

TeaM PAs	TeaM-Specific Goals	CMMI PAs	T-CMM (Chen)
P1.1 Determining Commitment (DCOM)	-Define Agreements on Duties (DAGD) -Agree upon Embedding into Curricula (AEC)	SD STSM	
P1.2 Availability of Resources (AR)	- Manage the Classroom Settings (MCS) - Manage the Technical Infrastructure (MTI)	SSD, CAM	CMC (SG 2)
P1.3 Discovering Needs (DN)	-Specify the Requirements (SREQ)	(REQM)*SSD	Course req.dev(CRD)
P2.1 Design Objectives (DO)	-Define the Course Aims and the Course Plan (DCAP) -Define the Quantitative and Qualitative Objectives for the Course (DQOQO)	QWM WP WP	Course & Teaching P.(CTP) QCM
P2.2 Content Planning (CP)	-Define the Learning Content (DLC) -Prepare and Integrate the Materials (PIM) -Define the Unit Schedule (DUS)		CTP CM ICTM
P2.3 Methodology Selection (MS)	-Analyze Methodologies to be Used (AMU) -Define the Methodologies to be Used (DMU)		
P2.4 Risk Management (RM)	-Identify Possible Problems (IPRO); -Analyze Possible Problems (APRO); -Establish Corrective Plan for Problems (ECP)	RSKM SCON	CTP
P3.1 Delivery and Consolidation (DC)	-Conduct Lessons According to Agreements/Plan (CLAA/P) -Adapt the Lessons based on Requirements (AL)	REQM	
P3.2 Assessment Management (AM)	-Define the Knowledge Test Criteria for the Delivered Units (DKT) -Implement the Knowledge Test (IKT)	MA	Learn. Verif. & Teach. Val. (VAL)
P4.1 Observing the Teaching Process (OTP)	-Monitor Teaching (against goals/plans in Initialization & preparation phase) (MT) -Aggregate the Monitoring Results (AMR) -Monitor Incidents (MONI)	PPQA (based on commitments) WMC MA DAR MA	Course M & C (CMC)
P4.2 Reflecting on the Teaching Process (RTP)	-Analyze the Results (from Observing the Teaching Process) (AR) -Define Corrective Actions (DCA)	IRP CAR CM DAR	
P4.3 Improving Teaching (IMT)	-Improve the Agreements and the Curricula (IAGC) - Improve the Classroom Settings and the Technical Infrastructure (ICTI) -Improve the Course Aims and the Plans (ICAP) -Improve the Learning Content (ILC) -Improve the Teaching Methodology (ITM) -Improve the Teachers Skills (ITS) -Deal with Incidents (DI)	OT OPF	Teach.Proc. Focus (TPF) Teaching Innovation (TIA)

Fig. 1. The TeaM model processes and goals (two first columns) represented somehow also by CMMI [2] (third column) and T-CMM [1](fourth column).

Due to the results from other researchers that used CMMI, we also assume that the CMMI backbone structure can be embedded in our research domain and therefore a detail explanation of the these components is presented below.

2 TeaM Model

For constructing the TeaM model, we kept the CMMI's basic terminology and structure (PAs, SP, SG, GP, GG, CL, ML), and so what was missing, was the new content (different from the CMMI and meaningful for our education domain) to be associated to each of the terminologies. Within the results from the study, the content was defined and presented in the below sections.

It is worth to mention that the results and the constructed TeaM model are discussed also with an expert of CMMI.

2.1 The Teaching Process.

Building up a maturity level means, firstly, defining what a teaching process is. Following the description from Meyer [3] and the results form the interviews, we defined the teaching as a process composed by four phases (Fig.2): *Initialization*– the phase where administrative issues of the teaching process are managed and defined; *Preparation*– the phase where teachers plan and prepare for the course; *Enactment*– the phase where the implementation of the teaching units takes place; *Quality and Incident Control*– the phase where possible incidents and the teaching process itself are observed, analyzed and refined.

The sub-phases of each phase helps later on to build up the one of main components of our TeaM model, named *Process Areas*, described below.

2.2 TeaM Representation.

One aspect of the TeaM model is that teaching is treated as a service where quality is of high relevance. For assessing the implementation of PAs, two representation paths are defined: a continuous representation (*Capability Level* – CL) and a stage representation (*Maturity Level* – ML). The continuous representation assesses and improves the process by focusing on an individual process areas. The stage representation assesses and improves the process by focusing on a set of process areas. We say that a process has improved when it upgrades the steps until the highest level is reached. Table 1 shows the features of the TeaM model related to Maturity and Capability levels. Unlike CMMI, TeaM has four levels for Capability and five levels for Maturity.

2.3 TeaM Process Areas.

The TeaM model has a total of 12 PAs (see Table.2), derived from the study results and based on the definition of the teaching process (Fig.2). Furthermore, from analyzing the results from interviews, the PAs are grouped into corresponding Maturity levels (Table.2). The PAs cover the following objectives:

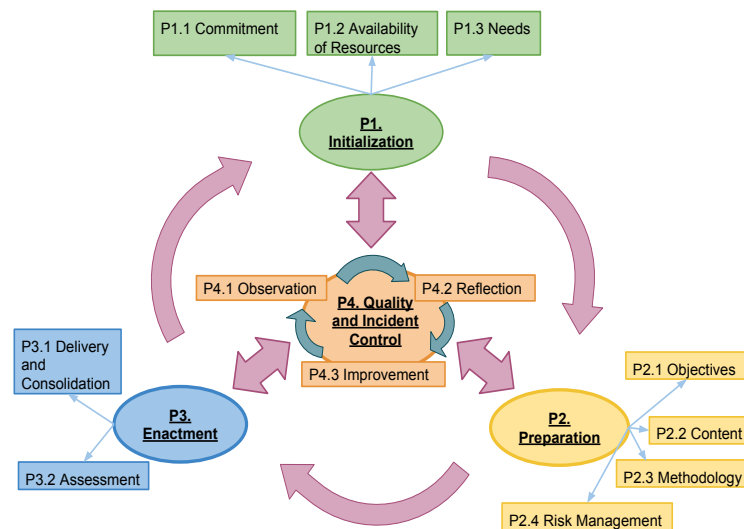

Fig. 2. The graphical representation of the teaching process.

Table 1. The Capability and Maturity levels of TeaM

Level	Capability Level
0	Deficient - None of the relevant factors of the teaching process are implemented.
1	Accomplished - The relevant factors of the teaching process are taken into consideration but there is no plan on implementing them.
2	Reflected - The relevant factors of the teaching process are planned and implemented in accordance to the policy. There is the plan for performing the process, resources are provided, responsibilities are taken, is controlled and monitored.
3	Defined - The relevant factors of the teaching process are standardized.

Level	Maturity Level
1	Chaotic - the teaching process is neither controlled nor efficient.
2	Initial - the teaching process is under minor control and little efficiency.
3	Repeatable - the teaching process is sparsely standardized and monitored.
4	Stable - the teaching process is standardized, monitored and controlled.
5	Optimizing - the teaching process is continuously improved and ready for further teaching process upgrades.

Table 2. The relevant Process Areas for each Maturity Level

Maturity Level	Process Areas
Chaotic (1)	No relevant PAs.
Initial (2)	Availability of Resources (AR) Design Objectives (DO) Content Planning (CP) Methodology Selection (MS) Delivery and Consolidation (DC) Assessment Management (AM)
Repeatable (3)	Determining Commitment (DCOM) Discovering Needs (DN) Risk Management (RM) Observing the Teaching Process (OTP)
Stable (4)	Reflecting on the Teaching Process (RTP)
Optimizing (5)	Improving Teaching (IMT)

P1.1 Determining Commitment (DCOM)- the responsibilities of all relevant stakeholders are defined and agreed upon/confirmed.

P1.2 Availability of Resources (AR)- the necessary and given environment and the infrastructure are dealt with.

P1.3 Discovering Needs (DN)- the requests from all the stakeholders are organized.

P2.1 Design Objectives (DO)- the course aims are defined.

P2.2 Content Planning (CP)- the information that has to be transmitted to the pupils/students is generated.

P2.3 Methodology Selection (MS)- teachers define the methods to be used for transmitting the information to pupils/students.

P2.4 Risk Management (RM)- incidents are foreseen and corrective plans are established.

P3.1 Delivery and Consolidation (DC)- teachers conduct their teaching units.

P3.2 Assessment Management (AM)- learning outcomes are evaluated.

P4.1 Observing the Teaching Process (OTP)- the other phases are assessed and measured.

P4.2 Reflecting on the Teaching Process (RTP)- the outcomes from the monitoring process are analyzed and corrective actions are derived.

P4.3 Improving Teaching (IMT)- corrective actions are implemented.

Like the CMMI's PA, the TeaM PA consists of Specific Goals (SG), which include Specific Practices (SP) and Generic Goals (GG), which include Generic Practices (GP). Specific Goals are unique to a PA, while Generic Goals are common for all PA (Fig.3). The latter have to do with the institutionalization of the Process Area (Capability Level). A Process Area should be satisfied in order to pretend its Maturity. In other words, the corresponding sets of Specific Practices associated to a Specific Goal should be fulfilled .

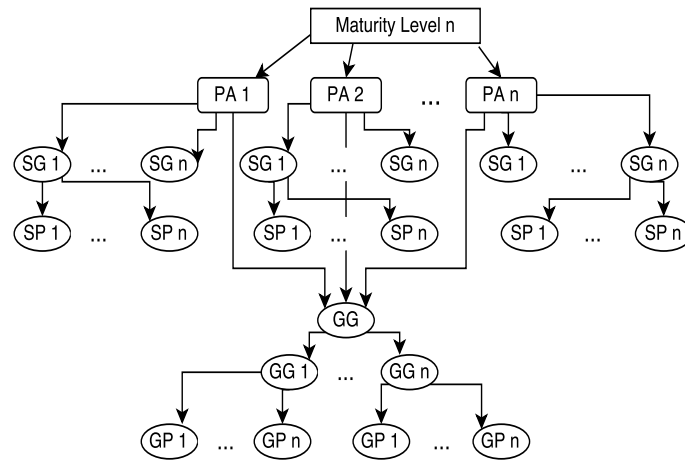

Fig. 3. The Specific and Generic Goals and Practices.

A Maturity level is achieved when all the Process Areas assigned to that level and to the previous levels reach the maximum Capability level. For example, to reach Maturity level 3 (Repeatable), level 2 should also be considered, and each of the Process Area assigned to Maturity level 2 (AR,DO, CP,MS, DC, AM) and Maturity level 3 (DCOM, DN, RM, OTP) must achieve Capability level 3. To reach Maturity level 4, all the Process Areas assigned to Maturity levels 2 (AR, DO, CP, MS, DC), 3 (DCOM, DN, RM, OTP) and 4 (RTP) must achieve Capability level 3 (the maximum level).

2.4 Specific Goals.

The assessment of a PA is correlated with the implementation of Specific and Generic Goals. The paper introduces the Specific Goals with the associated Specific Practices. When going in more details for each of the PAs of the TeaM model presented above, than the corresponding Specific Goals are:

- **(DCOM)**: Define Agreements on Duties (DAGD); Agree upon Embedding into Curricula (AEC)
- **(AR)**: Manage the Classroom Settings (MCS); Manage the Technical Infrastructure (MTI)
- **(DN)**: Specify the Requirements (SREQ)
- **(DO)**: Define the Course Aims and the Course Plan (DCAP); Define the Quantitative and Qualitative Objectives for the Course (DQOQO)
- **(CP)**: Define the Learning Content (DLC); Prepare and Integrate the Materials (PIM); Define the Unit Schedule (DUS)
- **(MS)**: Analyze Methodologies to be Used (AMU); Define the Methodologies to be Used (DMU)

- **(RM)**: Identify Possible Problems (IPRO); Analyze Possible Problems (APRO); Establish Corrective Plan for Problems (ECP)
- **(DC)**: Conduct Lessons According to Agreements/Plan (CLAA/P); Adapt the Lessons based on Requirements (AL)
- **(AM)**: Define the Knowledge Test Criteria for the Delivered Units (DKT); Implement the Knowledge Test (IKT)
- **(OTP)**: Monitor Teaching (against goals/plans in Initialization and preparation phase) (MT); Aggregate the Monitoring Results (AMR); Monitor Incidents (MONI)
- **(RTP)**: Analyze the Results (from Observing the Teaching Process) (AR); Define Corrective Actions (DCA);
- **(IMT)**: Improve the Agreements and the Curricula (IAGC); Improve the Classroom Settings and the Technical Infrastructure (ICTI); Improve the Course Aims and the Plans (ICAP); Improve the Learning Content (ILC); Improve the Teaching Methodology (ITM); Improve the Teachers Skills (ITS); Deal with Incidents (DI)

2.5 Specific Practices.

The Specific Practices are defined with the series of notation SPX.X.X.X

- P1.1 Determining Commitments (DCOM)
 - SG1.1.1 Define Agreements on Duties (DAGD)
 - SP1.1.1.1 Establish Responsibilities and Duties
 - SP1.1.1.2 Check for Formal Written Forms of Duties
 - SG1.1.2 Agree upon Embedding into Curricula (AEC)
 - SP1.1.2.1 Read the Curricula and the Position of your Course
 - SP1.1.2.2 Coordinate with the Colleagues
 - SP1.1.2.3 Reflect on Content with Colleagues for Optimization
- P1.2 Availability of Resources (AR)
 - SG1.2.1 Manage the Classroom Settings (MSC)
 - SP1.2.1.1 Arrange the Classroom Settings based on Methodology Used
 - SP1.2.1.2 Arrange the Classroom Atmosphere
 - SG1.2.2 Manage the Technical Infrastructure (MTI)
 - SP1.2.2.1 Check for the Available Technical Infrastructure
 - SP1.2.2.2 Plan What Devise to Use and When
- P1.3 Discovering Needs (DN)
 - SG1.3.1 Specify the Requirements (SREQ)
 - SP1.3.1.1 Predefine Previous Knowledge Requirements for a Course
 - SP1.3.1.2 Consider Requirements from other Stakeholders
 - SP1.3.1.3 Document the Requirements
- P2.1 Design Objectives (DO)
 - SG2.1.1 Define the Course Aims and the Course Plan (DCAP)
 - SP2.1.1.1 Control the Curricula for Defining Aims
 - SP2.1.1.2 Define the Year/Semester Course Plan

- SG2.1.2 Define the Quantitative and Qualitative Objectives for the Course (DQQO)
 - SP2.1.2.1 Define Measurable Objectives for the Course
 - SP2.1.2.2 Define Questions for Students to Measure the Objectives
 - SP2.1.2.3 Conduct the Questions during the Course or at the End or Both
- P2.2 Content Planning (CP)
 - SG2.2.1 Define the Learning Content (DLC)
 - SP2.2.1.1 Research and Collect Materials
 - SP2.2.1.2 Define Topics and Sub-topics
 - SP2.2.1.3 Discuss with Colleagues and Document Changes
 - SG2.2.2 Prepare and Integrate the Materials (PIM)
 - SP2.2.2.1 Select Available Materials based on the Course Aims and Content
 - SP2.2.2.2 Research and Integrate External Materials
 - SP2.2.2.3 Document the Materials
 - SP2.2.2.4 Discuss the Materials with Colleagues and Document Changes
 - SP2.2.2.5 Provide more than One Type of Materials
 - SG2.2.3 Define the Unit Schedule (DUS)
 - SP2.2.3.1 Plan the Unit Phases (lecture, practical, discussion etc.)
 - SP2.2.3.2 Assign Time to each Phase
 - SP2.2.3.3 Review and Document the Schedule
- P2.3 Methodology Selection (MS)
 - SG2.3.1 Analyze Methodologies to be Used (AMU)
 - SP2.3.1.1 Search for Available Methodologies
 - SP2.3.1.2 Considered Advantages and Disadvantages related to your Course Objectives
 - SG2.3.2 Define the Methodologies to be Used (DMU)
 - SP2.3.2.1 Consider Methodologies Effects on Learning Outcomes and Learner's Commitments
 - SP2.3.2.2 Compare and Choose those that best Fits to the Course Objectives
 - SP2.3.2.3 Implement the Methodologies
- P2.4 Risk Management (RM)
 - SG2.4.1 Identify Possible Problems (IPRO)
 - SP2.4.1.1 Consider and Document Problems on Classroom Settings/Technical Infrastructure
 - SP2.4.1.2 Consider and Document Problems with Unit Delivery
 - SG2.4.2 Analyze Possible Problems (APRO)
 - SP2.4.2.1 Analyze and Document the Problems
 - SG2.4.3 Establish Corrective Plan for Problems (ECP)
 - SP2.4.3.1 Define and Document a Corrective Plan for the Problems
- P3.1 Delivery and Consolidation (DC)
 - SG3.1.1 Conduct Lessons According To Agreements/Plan (CLAA/P)
 - SP3.1.1.1 Follow the Plan and the Unit Schedule
 - SP3.1.1.2 Inform Learners about the Plan and the Schedule
 - SP3.1.1.3 Arrange the Plan and Schedule when Time out
 - SP3.1.1.4 Identify Learner's Requirements
 - SG3.1.2 Adapt the Lesson based on Requirements (AL)

- SP3.1.2.1 Check if the Requirements Exist in the Corrective Plan
- SP3.1.2.2 Solve Immediate or Direct for the Next Unit
- P3.2 Assessment Management (AM)
- SG3.2.1 Define the Knowledge Test Criteria for the Delivered Units (DKT)
 - SP3.2.1.1 Define What to Assess based on the Course Objectives
 - SP3.2.1.2 Define Criteria during the Creation of Topics and Sub-Topics
 - SP3.2.1.3 Consider Conceptual and Application Knowledge
- SG3.2.2 Implement the Knowledge Test (IKT)
 - SP3.2.2.1 Define the Type of the Assessment (test, project, etc.)
 - SP3.2.2.2 Define the Form of the Assessment (online, paper and Pencil, etc.)
 - SP3.2.2.3 Manage the Environment Settings for the Assessment
 - SP3.2.2.4 Apply the Assessment
 - SP3.2.2.5 Analyze and Discuss the Result
 - SP3.2.2.6 Collect and Analyze Learner's Inputs
- P4.1 Observing the Teaching Process (OTP)
- SG4.1.1 Monitor Teaching (from Initialization and Preparation phase) (MT)
 - SP4.1.1.1 Check Time Plan during the Lesson or Directly after it
 - SP4.1.1.2 Check Objectives compared by Learners Output
 - SP4.1.1.3 Check the Effect of the Teaching Methodology
- SG4.1.2 Aggregate the Monitoring Results (AMR)
 - SP4.1.2.1 Document Results from Time Plan Observation
 - SP4.1.2.2 Document Results from Learners Input during the Lesson or after it
 - SP4.1.2.3 Document the Results from Teaching Methodology
- SG4.1.3 Monitor Incidents (MONI)
 - SP4.1.3.1 Document Problems during Teaching Process
- P4.2 Reflecting on the Teaching Process (RTP)
- SG4.2.1 Analyze the Results (from P4.1) (AR)
 - SP4.2.1.1 Do a Periodically Analyzation of the good and bad Experiences during Observation
 - SP4.2.1.2 Reflect about with colleagues
 - SP4.2.1.3 Document the Results
- SG4.2.2 Define Corrective Action (DCA)
 - SP4.2.2.1 Take Corrective Action for bad Experiences and Document it
- P4.3 Improve Teaching (IMT)
- SG4.3.1 Improve the Agreements and the Curricula (IAGC)
 - SP4.3.1.1 Based on Monitor and Analyzation establish Changes
 - SP4.3.1.2 Discuss with Colleagues
 - SP4.3.1.3 Document
- SG4.3.2 Improve the Classroom Settings and the Technical Infrastructure (ICTI)
 - SP4.3.2.1 Look for new Possibilities
 - SP4.3.2.2 Integrate and Test them in your Environment
 - SP4.3.2.3 Document the Test Results
- SG4.3.3 Improve the Course Aims and the Plans (ICAP)
 - SP4.3.3.1 Based on Monitoring and Analyzation Improve on Objectives and Plans

- SP4.3.3.2 Document the Improvement
- SG4.3.4 Improve the Learning Content (ILC)
 - SP4.3.4.1 Based on Monitoring and Analyzation Improve the Learning Content
 - SP4.3.4.2 Document the Improvement
- SG4.3.5 Improve the Teaching Methodology (ITM)
 - SP4.3.5.1 Based on Monitoring and Analyzation Define and Document if Methodology should be changed
- SG4.3.6 Improve the Teachers Skills (ITS)
 - SP4.3.6.1 Do a periodically Training on Personal Skills
- SG4.3.7 Deal with Incidents (DI)
 - SP4.3.6.1 Take Corrective Action for Occurred Incidents

References

1. Chung-Yang Chen, Pei-Chi Chen, and Pei-Ying Chen. Teaching quality in higher education: An introductory review on a process-oriented teaching-quality model. *Total Quality Management & Business Excellence*, 25(1-2):36–56, 2014.
2. Eileen C. Forrester, Brandon L. Buteau, and Sandy Shrum. *CMMI for Services: guidelines for superior service*. Pearson Education, 2011.
3. Hilbert Meyer. *Was ist guter Unterricht? Mit didaktischer Landkarte*. Cornelsen, 2016.